

# 42" x 33" Media Tower

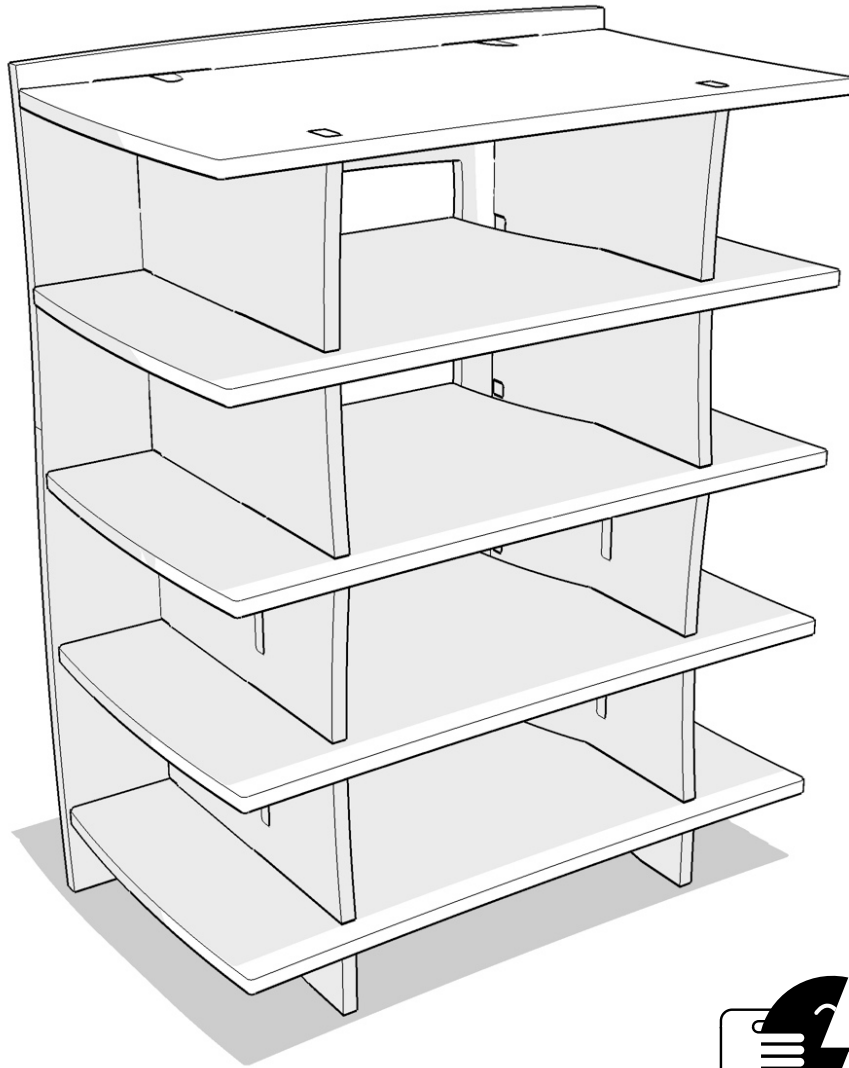

# Shelf Rails

Before assembling your media unit, you should decide if you wish to leave out a shelf to provide room for a large piece of equipment, such as a television. You can always remove a shelf later, but you will need to disassemble and reassemble the unit to do so.

If you choose to leave out a shelf, you can install the supplied rails to fill the empty shelf slots. Simply slide the rails into the empty slots as shown here.

1

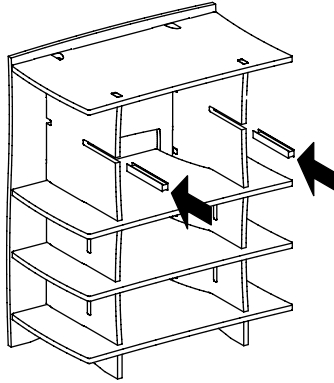

2

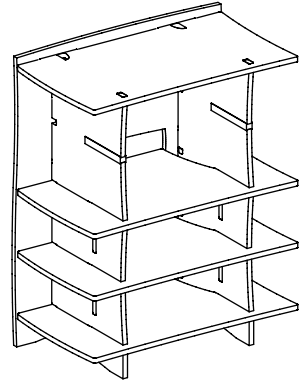

# Connectors

If you have more than one Legare media unit, you should decide if you wish to lock two of your units together before assembling your media tower.

You will need to assemble the shelving and back panel of the tower so that the curvature of the edges matches the curvature of the edges of the unit you are placing it next to.

After assembling the two units, simply pull the units together and insert the supplied connectors as shown here.

The connectors provide a back-stop for CD and DVD cases so that they can be stored like books in a bookcase, instead of being pushed rearward and lost at the back of the shelves between the units.

1

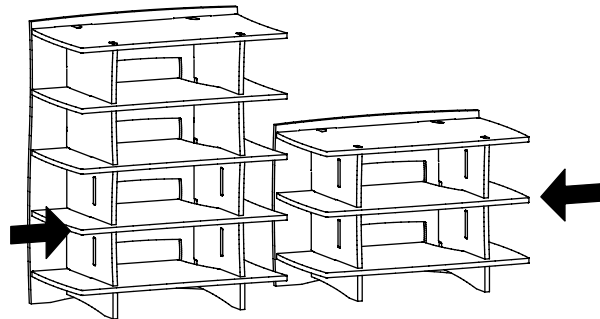

2

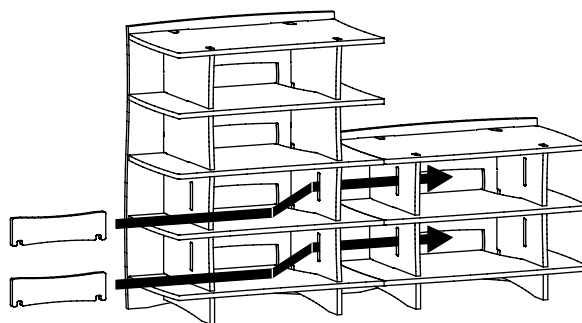

3

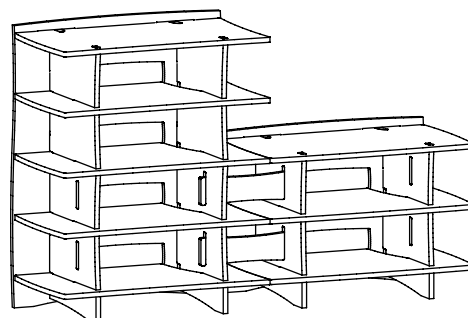

# Assembly

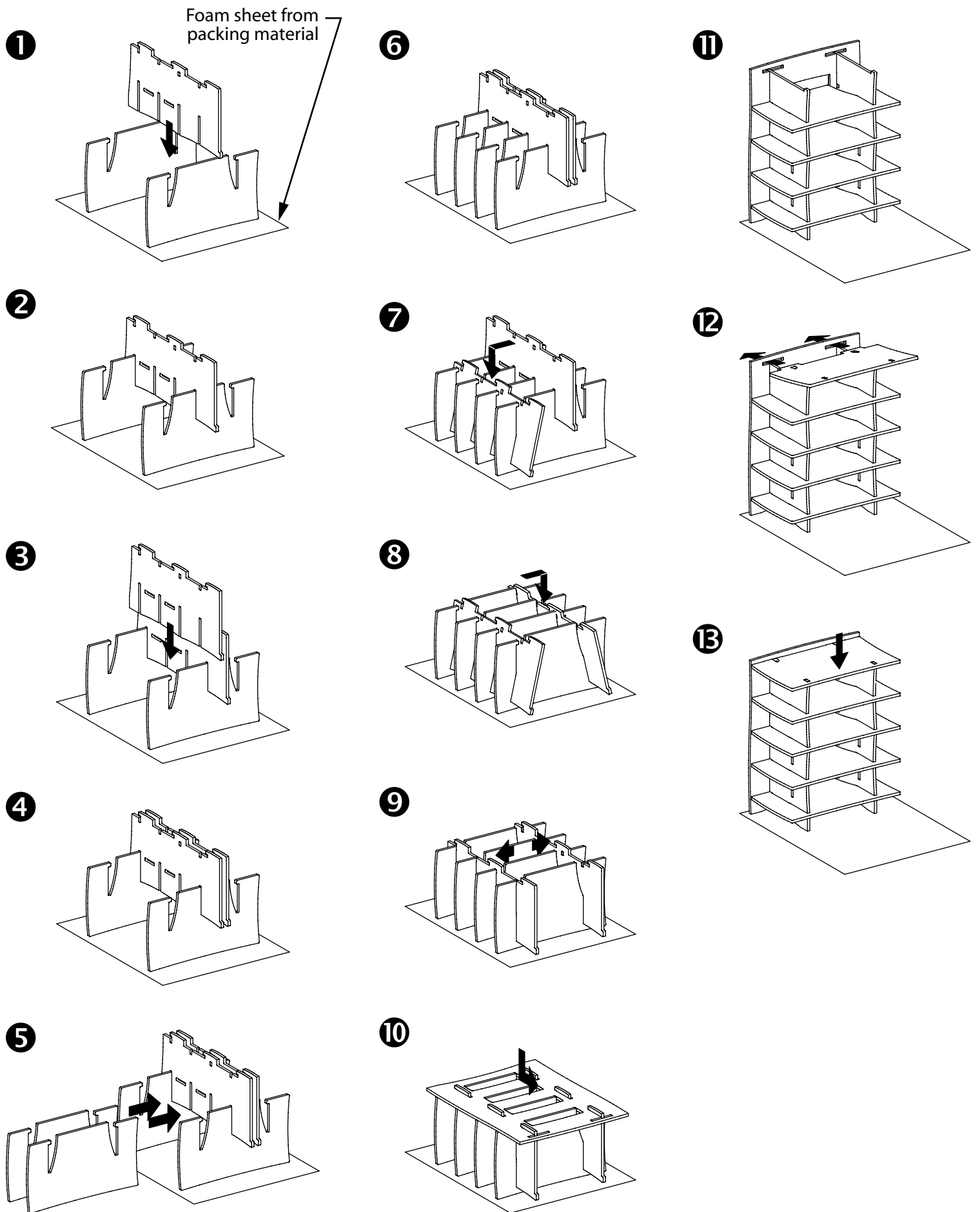

# Care & Finishing

Thank you for the purchase of your new Legaré product. We certainly hope that it serves you well for many years to come.

Depending upon the finish of your particular components, there are few things that you should do to protect its finish or to insure that the finish that you put on it does not cause you any problems.

## Pre-Finished Parts

Parts finished with a lacquer finish require little more than a light coat of lemon oil or furniture polish to make assembly easier and preserve the finish. Doing this before assembling the parts will prevent chafing and will make the parts easier to slide together.

Before putting any heavy objects with plastic or rubber feet on the horizontal surfaces, you should be aware that some materials can discolor the finishes on furniture. Plastics will release plasticizers which can penetrate and stain some finishes. If your equipment has black plastic or rubber feet, put something between the equipment and the surface to protect the finish. Applying a coat of furniture polish or wax can help in many cases, but will not always eliminate the problem. A pad or mat between the surface and the item is the best solution.

## Un-Finished Parts

When finishing Legaré furniture yourself, the most important thing to consider is the build-up of any finish that you put on the parts. The Legaré panels are designed with some clearance between the tabs and slots in order to accommodate the build-up of a lacquer finish. If you intend to simply stain your parts, you should not have any problems. However, if you intend to add a sealer or a thick coat of urethane or lacquer, you need to consider the thickness that these finishes can add to the parts. You may need to sand the tabs and slots further if your build-up will exceed 5 or 6 mil (.005"-.006") per side to insure that the panels will still fit together properly.

When doing any sanding, remember that not all edges are critical. You can save yourself a good amount of labor by not spending excessive time sanding and preparing edges that you will not see or touch. Also, if you intend to put on a sealer, it is not necessary to sand the surfaces to a mirror finish as the sealer will tend to fill in the surface roughness of the material. If you should need to touch up any gouges or scratches, you can use a small amount of wood dough the color of your final finish. Should any splinters occur along an edge, simply use normal wood glue to re-bond a splinter. And should you need to touch up any edges, use a small trim router with a 3/16" radius round-over bit.

And remember, because Legaré is a natural wood product, the resulting finish may vary from piece to piece whether the parts come pre-finished or you finish them yourself.

# Contents

